

TB-GEN014

TECHNICAL BULLETIN

INFORMATION ONLY

For the Attention of : Graham Mears, Larry Power, Sales Team, Estimators, Testers, CDO

From: Pete Canning – Product Support Manager (Passenger Lifts)

Date : 21 August 2016

Subject : **MP & Kleemann Pit Ladders - Structure**

Product: All

Pages : 3

Background

There has been a little confusion on how the pit ladder should be fitted on the FX Structure for the MP and Kleemann EN81 – 20 pit ladders. Below you will see the MP and Kleemann solutions.

Kleemann Pit ladder fitted to the FX Structure.



Part number for the Kleemann FX Structure.

29	 <p>Support channels – for foldable pit ladder</p>	1000066	2
----	---	---------	---

MP Pit ladder fitted to the FX Structure.

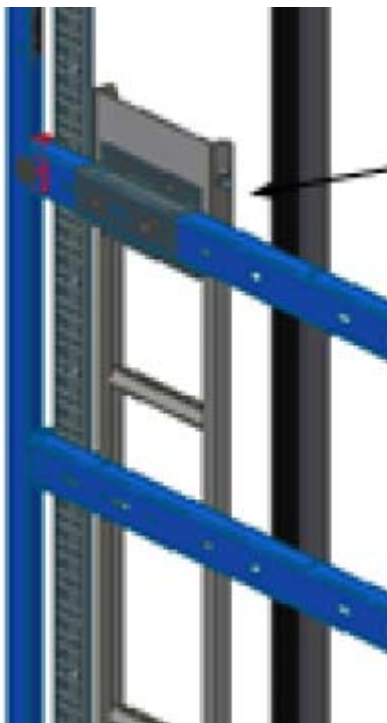

An additional structure ring member will be provided with an extra guide plate as seen in the photo above.

Part number for the MP FX Structure.

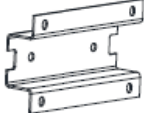
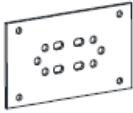
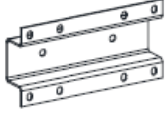
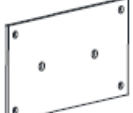
9	 <p>Ring member – both guide sides - depth</p>	100030-1731 or 100030-1766 or 100030-1686	Depends on lift travel
10	 <p>Guide support bracket</p>	1000054	Depends on lift travel
11	 <p>Guide mounting plate</p>	1000056	
12	 <p>Guide support bracket (300 wide)</p>	1000055	2-off (for top car guide fixing on c/w side + pit ladder) on lifts with 2S doors
13	 <p>Guide mounting plate (300 wide)</p>	1000057	Depends on lift travel for lifts with 2C doors.

Please note

Please ensure that the ladder is fitted before you run your trunking and the pit equipment to avoid anything clashing.

I hope you all find this Bulletin to be of help and should you have any questions about this topic or would like to know a little more then please contact me on **Ext 8646 or DDI 01264 343646**

Pete Canning